

Foundation Gas/Electric Rooftop

Unit Overview - GCC240A4EHA**070000000000000000000000

Application	Unit Size	Supply Fan		External Dimensions (in.)			Operating Weight		EER	IEER/SEER	Elevation
		Airflow	External Static Pressure	Height	Width	Length	Minimum	Maximum			
Gas/Electric	20 Ton	8000 cfm	0.500 in H2O	4.94 ft	7.24 ft	10.26 ft	2025.0 lb	2439.0 lb	10.00	13.20	

Unit Features

SupplyFan/Drive/ MotorType Two speed fan standard motor



Unit Electrical

Voltage/phase/hertz 460/60/3

MCA 53.00 A

MOP 60.00 A

Controls

Unit Controls Electro-mechanical

Cooling Section

		Capacity
Entering Dry Bulb	80.00 F	Gross Total 257.71 MBh
Entering Wet Bulb	67.00 F	Gross Sensible 186.58 MBh
Ambient Temp	95.00 F	Net Total 245.00 MBh
Leaving Coil Dry Bulb	58.49 F	Net Sensible 173.86 MBh
Leaving Coil Wet Bulb	56.77 F	Refrig Charge-circuit 1 24.4 lb
Leaving Unit Dry Bulb	60.32 F	
Leaving Unit Wet Bulb	57.49 F	

Heating Section

Output Heating Capacity	308.00 MBh
Output Heating Capacity with Fan	308.00 MBh
Heating EAT	70.00 F
Heating LAT	105.48 F
Heating Temp Rise	35.48 F

Fan Section

Indoor Fan Data		Outdoor Fan Data	
Type	FC Centrifugal	Type	Propeller
Drive Type	Belt	Fan Quantity	2
Indoor Fan Performance		Drive Type	Direct
Airflow	8000 cfm	Outdoor Fan Performance	
Design ESP	0.500 in H2O	Condenser Fan FLA	5.00 A
Component SP	0.000 in H2O	Exhaust Fan Data	
Total SP	0.500 in H2O	Type	FC Centrifugal
Indoor Motor Operating Power	3.70 bhp	Drive Type	Direct
Indoor Motor Power	2.76 kW	Exhaust Fan Performance	
Indoor RPM	869 rpm	Exhaust Fan FLA	7.60 A

Compressor Section

Circuit 1 RLA	16.80 A
Circuit 2 RLA	15.50 A

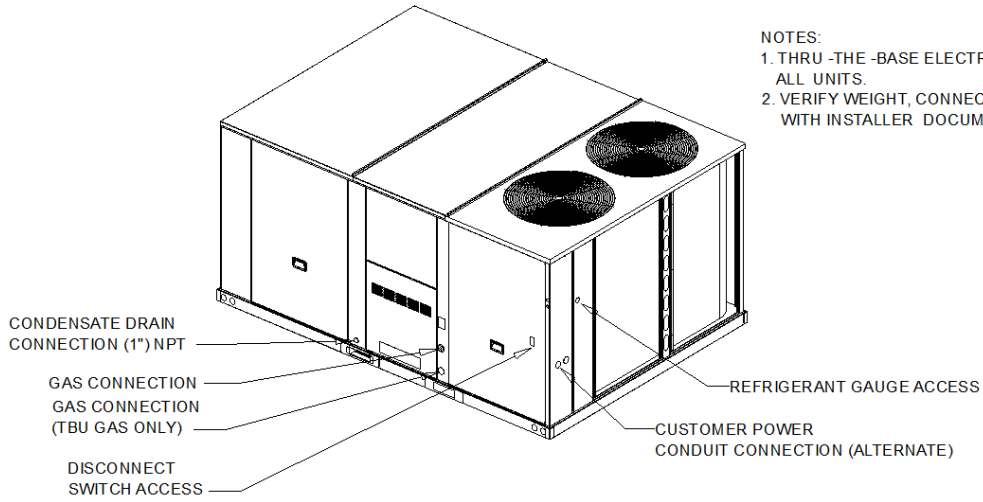

- NOTES:
1. THRU -THE -BASE ELECTRICAL IS NOT STANDARD ON ALL UNITS.
 2. VERIFY WEIGHT, CONNECTIONS, AND ALL DIMENSIONS WITH INSTALLER DOCUMENTS BEFORE INSTALLATION

PACKAGED GAS / ELEC DOWNFLOW

DIMENSION DRAWING

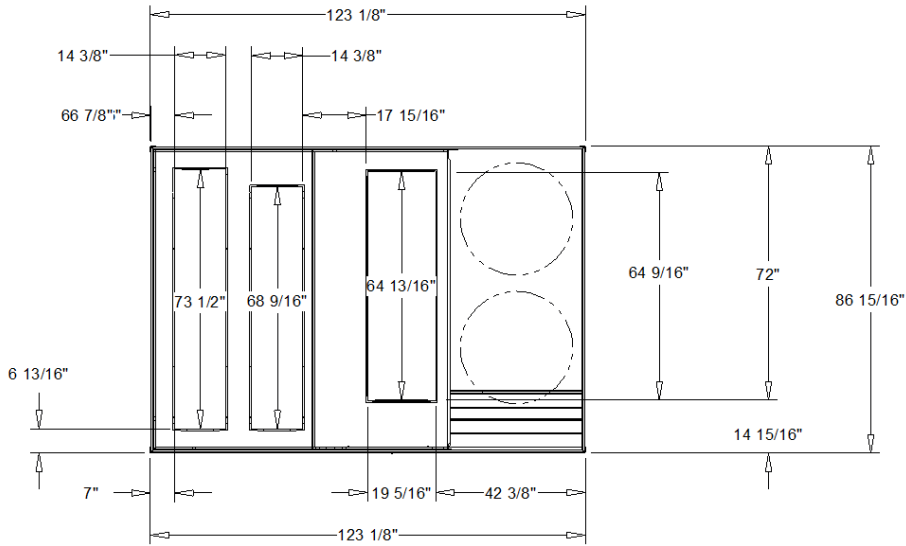

PLAN VIEW OF UNIT

DIMENSION DRAWING

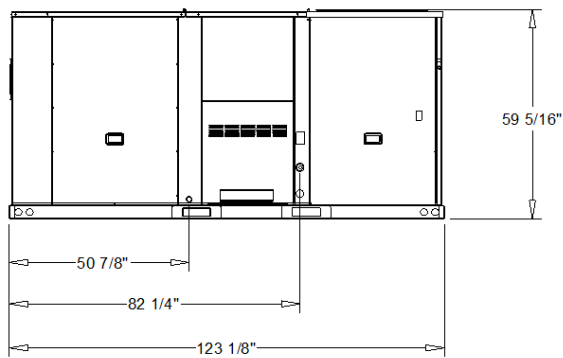

FRONT VIEW OF UNIT

DIMENSION DRAWING

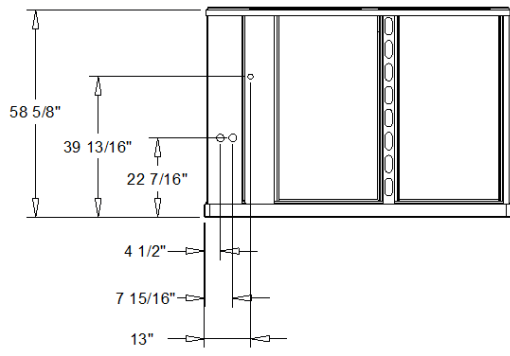

RIGHT VIEW OF UNIT

DIMENSION DRAWING

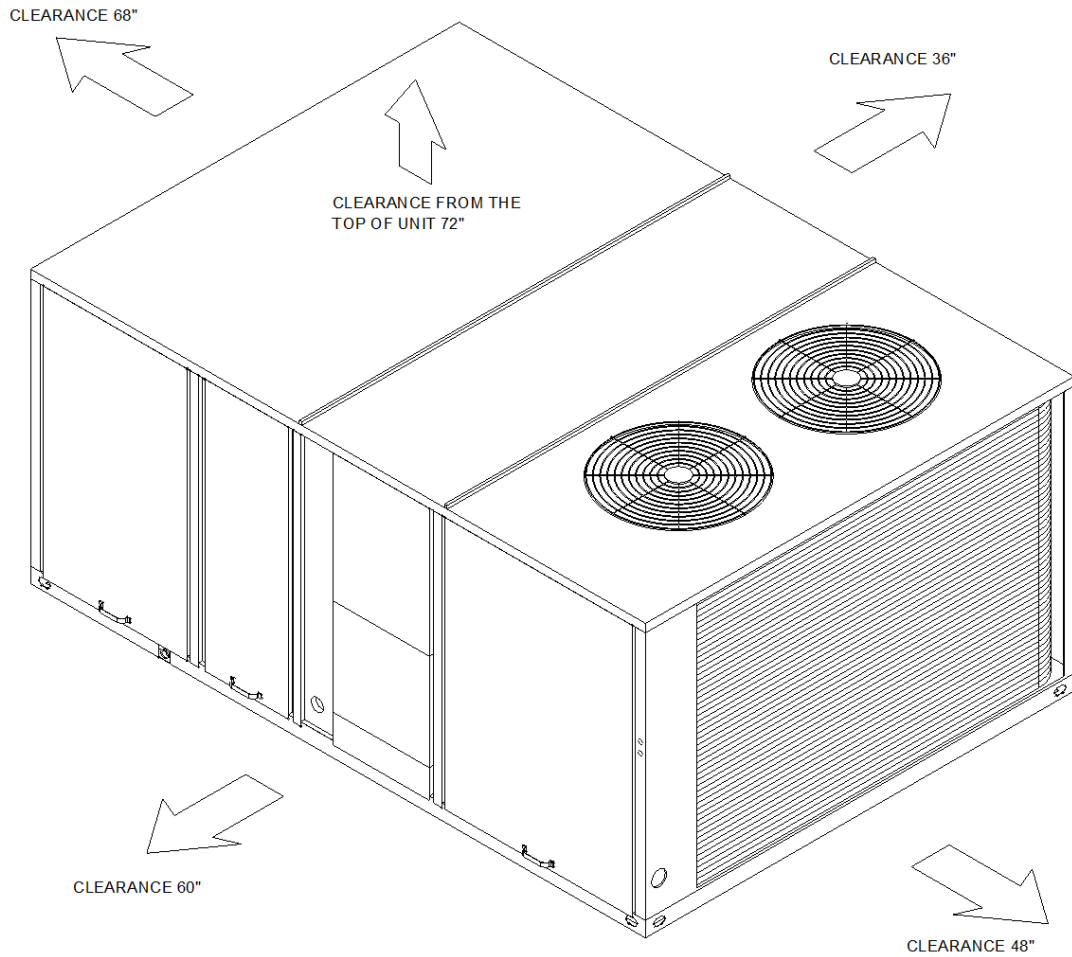

DOWNFLOW-PACKAGED COOLING WITH ELECTRIC CLEARANCE

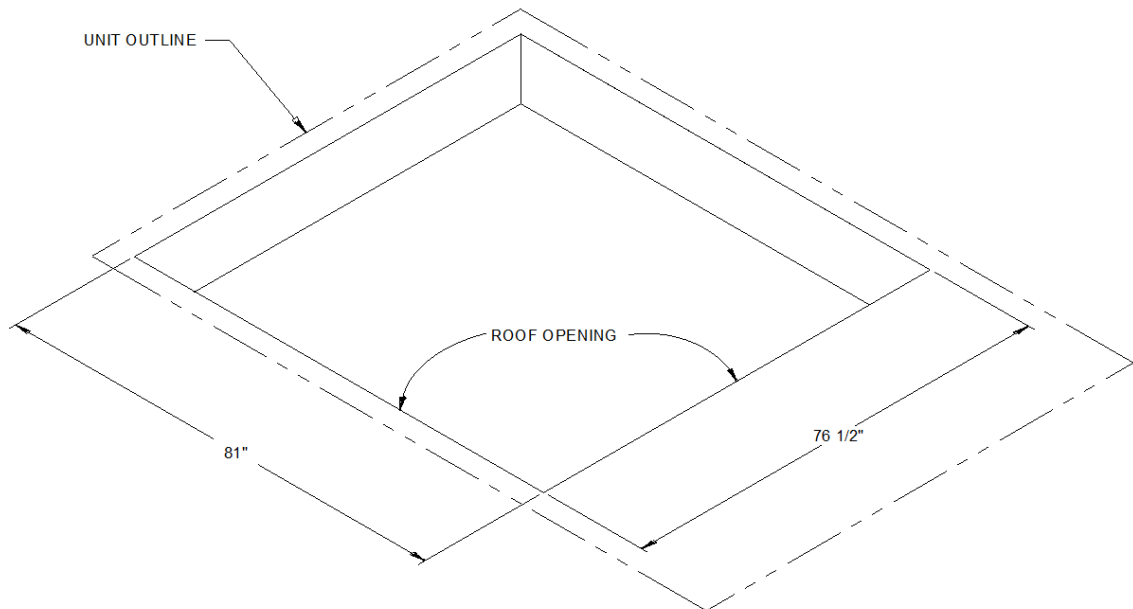

DOWNFLOW-PACKAGED COOLING WITH ELECTRIC ROOF OPENING CLEARANCE

INSTALLED ACCESSORIES NET WEIGHT DATA

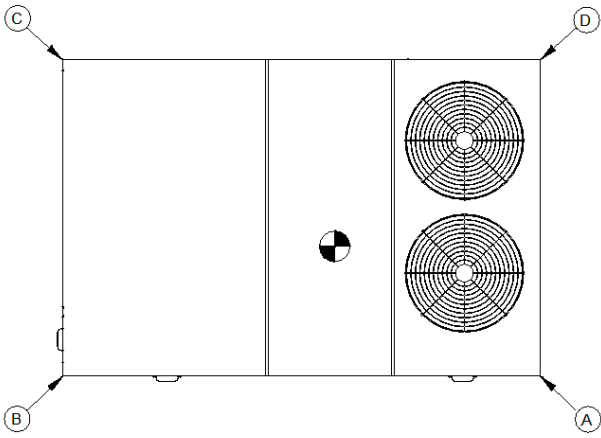

CORNER WEIGHT

ACCESSORY		WEIGHTS			
ECONOMIZER					
MOTORIZED OUTSIDE AIR DAMPER					
MANUAL OUTSIDE AIR DAMPER					
OVERSIZED MOTOR					
MULTI-SPEED WITH DRIVE		65.0 lb			
THROUGH THE BASE ELECTRICAL					
BAROMETRIC					
ROOF CURB					
POWER EXHAUST					
HAIL GUARD					
LP GAS CONVERSION					
STATIC DRIVE					
DISCONNECT					
BASE UNIT WEIGHTS		CORNER WEIGHTS		CENTER OF GRAVITY	
SHIPPING	NET	(A)	(C)	(E) LENGTH	(F) WIDTH
2350.0 lb	2025.0 lb	(B) 512.0 lb	(D) 466.0 lb	55"	37.0 lb

NOTE:

1. All weights are approximate.
2. The actual weight are listed on the unit nameplate.
3. Refer to unit nameplate and installation guide for weights before scheduling transportation and installation of unit.
4. The weight shown represents the typical unit operating weight for the configuration selected. Estimated at +/- 10 % of the nameplate weight.
5. Verify weight, connection, and all dimension with installer documents before installation.
6. Corner weights are given for information only.
7. Net/Shipping weight of optional accessories should be added to unit weight when ordering factory or field installed accessories.
8. Weights for options are approximate.
9. Weights for options that are not list refer to Installation guide.

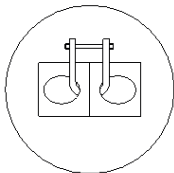
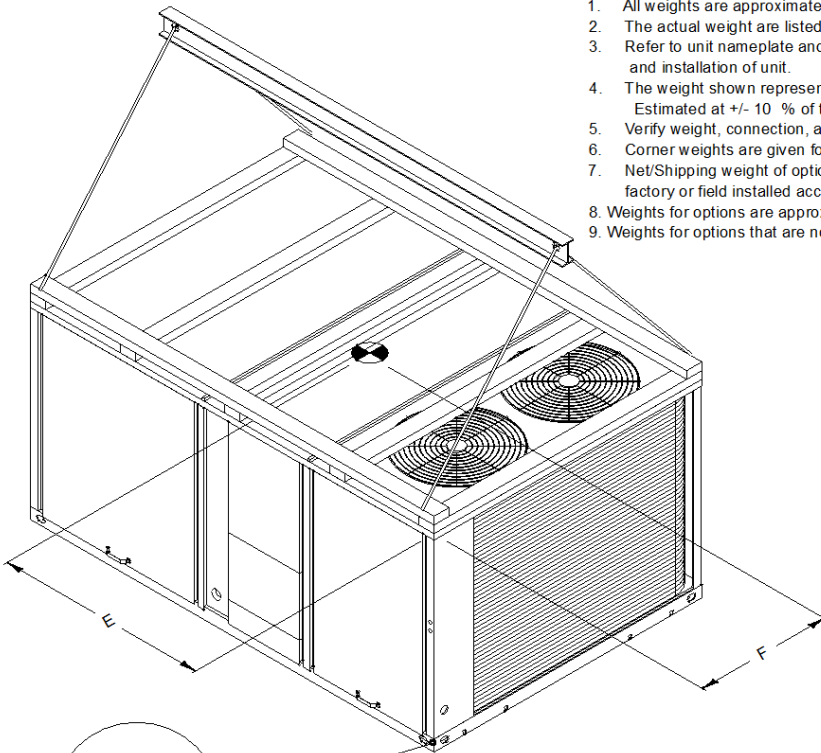

RIGGING AND CENTER OF GRAVITY

15 thru 25 Ton General

The units shall be dedicated downflow or horizontal airflow. The operating range shall be between 115°F and 40°F in cooling as standard from the factory for all units. Cooling performance shall be rated in accordance with ARI testing procedures. All units shall be factory assembled, internally wired, fully charged with R-410A, and 100 percent run tested to check cooling operation, fan and blower rotation and control sequence, before leaving the factory. Wiring internal to the unit shall be colored and numbered for simplified identification. Units shall be UL listed and labeled, classified in accordance to UL 1995/C 22.2, 236-05 3rd Edition.

15 thru 25 Ton Casing

Unit casing shall be constructed of zinc coated, heavy gauge, galvanized steel. Exterior surfaces shall be cleaned, phosphatized, and finished with a weather-resistant baked enamel finish. Unit's surface shall be tested 672 hours in a salt spray test in compliance with ASTM B117. Cabinet construction shall allow for all maintenance on one side of the unit. In order to ensure a water and air tight seal, service panels shall have lifting handles and no more than three screws to remove. All exposed vertical panels and top covers in the indoor air section shall be insulated with a 1/2", 1.0 lbdensity foil-faced, fire-resistant, permanent, odorless, glass fiber material. The base of the downflow unit shall be insulated with 1/2", 1.0 lbdensity foil-faced, closed-cell material. The downflow unit's base pan shall have no penetrations within the perimeter of the curb other than the raised 1 1/8"high supply/return openings to provide an added water integrity precaution, if the condensate drain backs up. The base of the unit shall have provisions for forklift and crane lifting.

15 thru 25 Ton Compressors

All units shall have direct-drive, hermetic, scroll type compressors with centrifugal type oil pumps. Motor shall be suction gas-cooled and shall have a voltage utilization range of plus or minus 10 percent of nameplate voltage. Internal overloads shall be provided with the scroll compressors. All models shall have phase monitors and low and high pressure control as standard.

15 thru 25 Ton Controls

Unit shall be completely factory wired with necessary controls and contactor pressure lugs or terminal block for power wiring. Unit shall provide an external location for mounting a fused disconnect device.

15 thru 25 Ton Discharge Line Thermostat

A bi-metal element discharge line thermostat is installed as a standard option on the discharge line of each system. This standard option provides extra protection to the compressors against high discharge temperatures in case of loss of charge, extremely high ambient and other conditions which could drive the discharge temperature higher. Discharge line thermostat is wired in series with high pressure control. When the discharge temperature rises above the protection limit, the bi-metal disc in the thermostat switches to the off position, opening the 24 Vac circuit. When the temperature on the discharge line cools down, the bi-metal disc closes the contactor circuit, providing power to the compressor.

15 thru 25 Ton Evaporator and Condenser Coils

Microchannel coils will be burst tested by the manufacturer. Internally finned, 5/16" copper tubes mechanically bonded to a configured aluminum plate fin shall be standard for evaporator coils. Microchannel condenser coils shall be standard on all units. Coils shall be leak tested to ensure the pressure integrity. The evaporator coil and condenser coil shall be leak tested to 225 psig and pressure tested to 450 psig. Sloped condensate drain pans are standard.

15 thru 25 Ton Filters

Two inch standard filters shall be factory supplied on all units.

15 thru 25 Ton Gas Heating Section

The heating section shall have a progressive tubular heat exchanger design. An induced draft combustion blower shall be used to pull the combustion products through the firing tubes. The heater shall use a direct spark ignition (DSI) system. On initial call for heat, the combustion blower shall purge the heat exchanger for 20 seconds before ignition. After three unsuccessful ignition attempts, the entire heating system shall be locked out until manually reset at the thermostat. Units shall be suitable for use with natural gas or propane (field-installed kit) and also comply with the California requirement for low NOx emissions (Gas/Electric Only).

15 thru 25 Ton High Pressure Control

All units include High Pressure Cutout as standard.

15 thru 25 Ton Indoor Fan

Units above shall have belt driven, FC centrifugal fans with adjustable motor sheaves. Units with standard motors shall have an adjustable idler-arm assembly for quick-adjustment of fan belts and motor sheaves. All motors shall be thermally protected. Oversized motors shall be available for high static application. All indoor fan motors meet the U.S. Energy Policy Act of 1992 (EPACT).

15 thru 25 Ton Low Pressure Control

All units include Low Pressure Cutout as standard.

15 thru 25 Ton Outdoor Fans

The outdoor fan shall be direct-drive, statically and dynamically balanced, draw-through in the vertical discharge position. The fan motor(s) shall be permanently lubricated and shall have builtin thermal overload protection.

15 thru 25 Ton Phase Monitor

The Phase Monitor is a three-phase line monitor module that protects against phase loss, phase reversal and phase unbalance. It is intended to protect compressors from reverse rotation. It has an operating input voltage range of 190-600 Vac, and LED indicators for ON and FAULT. There are no field adjustments and the module will automatically reset from a fault condition.

15 thru 25 Ton Refrigerant Circuits

Each refrigerant circuit shall have independent fixed orifice, service pressure ports, and refrigerant line filter driers factory installed as standard. An area shall be provided for replacement suction line driers.

15 thru 25 Ton Unit Top

The top cover shall be double hemmed and gasket sealed to prevent water leakage.

15 thru 25 Ton Multi-Speed Indoor Fan System

Multi-speed indoor fan system is designed for use in applications for meeting the minimum requirement of CA Title 24. This system incorporates a multi-speed fan control to change the speed of the fan to 66% of full airflow based off of compressor stages.